



Dual Strobe Expander Plates for Emergency Communications

The new SpectrAlert® Advance Dual Strobe and Dual Strobe with Speaker Expander Plates lower costs and improve aesthetics by performing the functions of 2-3 devices for emergency communications applications.



SEP-SPSW Speaker Strobe Expander Plate
(Speaker Strobe Device Sold Separately)

SEP-SW Strobe Expander Plate



Features

- UL 1638-Listed amber lens strobe
- Meets DOD specification requirements
- Field-selectable candela settings:
Standard: 15, 15/75, 30, 75, 95, 110, 115
(please refer to Equivalent Candela Rating for UL 1971 Table)
- Automatic selection of 12- or 24-volt operation at 15 and 15/75 candela
- Compatible with System Sensor synchronization protocol
- Optional tamper-resistant Torx head screw included
- Designed to be used in 12 or 24 volt, DC or FWR systems
- Rated from 32°F to 120°F
- SEP-SPSW is compatible with: SPSW, SPSWH, SPSW-P, SPSWV, SPSWV-P, SPSWH-P
- SEP-SW is compatible with: SW, SWH, SW-P, SWH-P
- Listed for ceiling or wall mounting

Cut costs, speed installation, and improve aesthetics on emergency communications applications that require fire and emergency warnings by combining the functions of two to three devices on a single mounting plate and back box. SpectrAlert Advance Dual Strobe and Dual Strobe with Speaker Expander Plates provide dual strobe and speaker strobe functionality that's easy for a single person to wire and install. Simply mount the plate to a junction box and connect the field wiring to the terminals. To complete the installation, hinge and attach the strobe or speaker strobe device with a single captured mounting screw.

Dual Strobe and Dual Strobe with Speaker Expander Plates are designed to be used in 12 or 24 volt, DC or FWR (full wave rectified) systems. Amber lens strobes are UL 1638-Listed (Visual Signaling Appliances) for Private Mode General Utility Signaling. A table is also provided to show the candela rating per the UL 1971 test procedures. All SpectrAlert Advance products are suitable for use in synchronized systems. The System Sensor MDL module may be used to provide synchronization.

Agency Listings



S4048



7320-1653:201



MEGA approved

10-08-E

Dual Strobe and Dual Strobe with Speaker Expander Plate Specifications

Electrical/Operating Specifications	
Operating Temperature	32°F to 120°F (0°C to 49°C)
Humidity Range	10 to 93% non-condensing
Strobe Flash Rate	1 flash per second
Nominal Voltage (strobes)	Regulated 12VDC/FWR or regulated 24DC/FWR
Operating Voltage Range (includes fire alarm panels with built in sync)	8 to 17.5V (12V nominal) or 16 to 33V (24V nominal)
Operating Voltage with MDL Sync Module	9 to 17.5V (12V nominal) or 17 to 33V (24V nominal)
Input terminal wire gauge	12 to 18 AWG
Dimensions (Expander Plate Only)	
SEP-SW	4 in x 4 in x 1.5 in single gang, double gang, 4 in octagon
SEP-SPSW	4 in x 4 in x 2.125 in or deeper
Dimensions (Expander Plate with Strobe or Speaker Strobe Device)	
SEP-SW & SEP-SPSW	L 9.6 in (245 mm) W 5.1 in (130 mm) D 3.7 in (94 mm)
SPSEP-BBSW & SEP-BBSW	L 10.1 in (257 mm) W 5.6 in (142 mm) D 2.5 in (64 mm)
Dimensions (Back Box Skirts)	
SPSEP-BBSW & SEP-BBSW	4 in x 4 in x 2.125 in

UL Current Draw Data

UL Max. Strobe Current Draw (mA) for SEP-SW, SEP-SPSW (Amber Strobe Only)					
	Candela	8 to 17.5 Volts		16 to 33 Volts	
		DC	FWR	DC	FWR
Standard	15	123	128	66	71
Candela Range	15/75	142	148	77	81
	30	NA	NA	94	96
	75	NA	NA	158	153
	95	NA	NA	181	176
	110	NA	NA	202	195
	115	NA	NA	210	205
Candela Derating for Amber Lens Strobe					
	Cd Switch Setting	On-Axis Rating (UL 1638)	Equivalent Cd Rating for Wall profile (UL 1971*)		
	15	15	12		
	15/75	15/75	15/75		
	30	30	24		
	75	75	60		
	95	95	75		
	110	110	85		
	115	115	90		

*Note: UL 1971 is not applicable to emergency communication devices, but these readings were obtained using the measurement procedure specified under UL 1971.

Dimensions

SEP-SPSW – Speaker Strobe Expander Plate

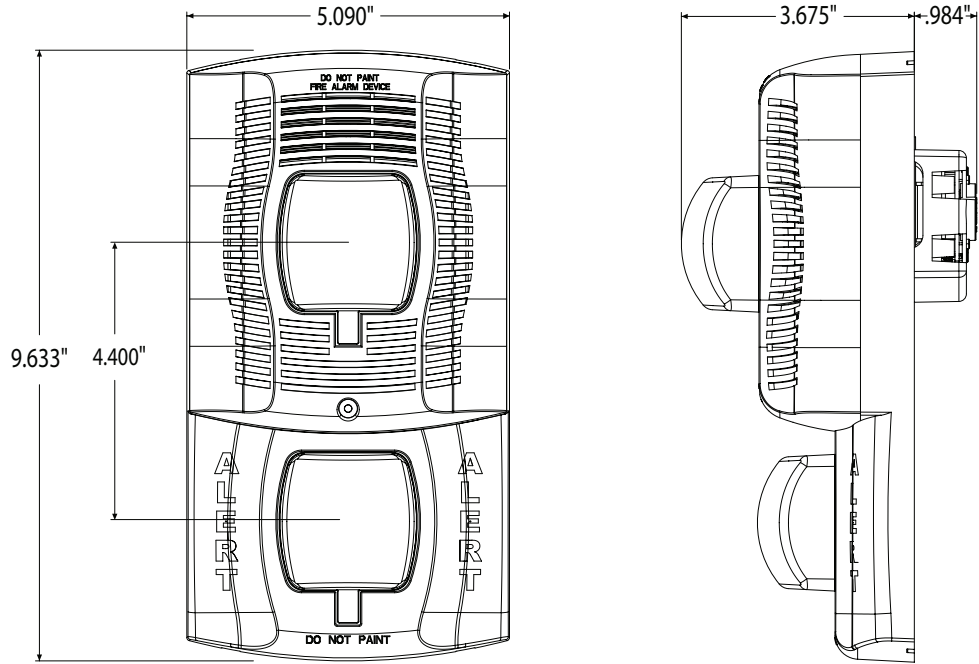

SEP-SW – Strobe Expander Plate

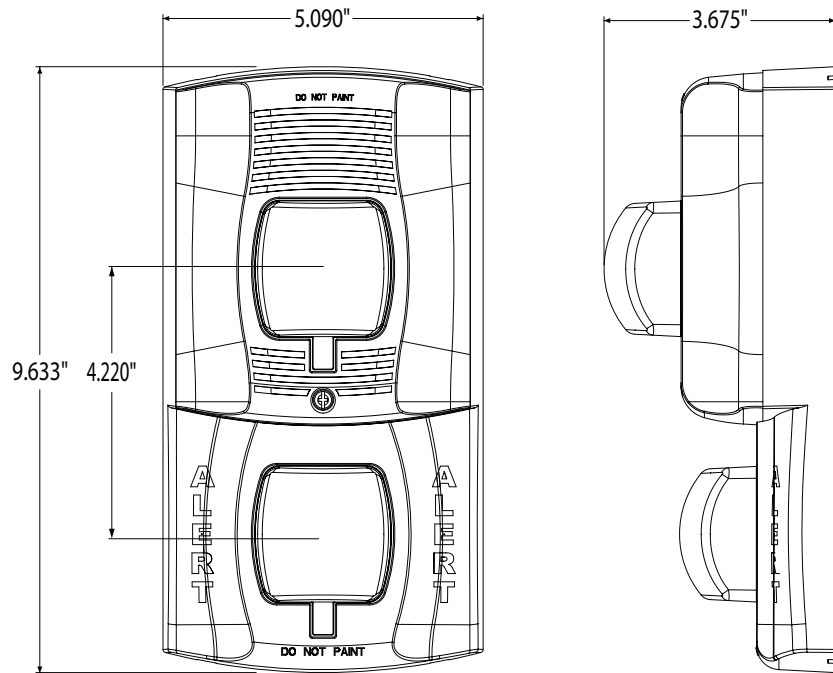

Flush Mounting

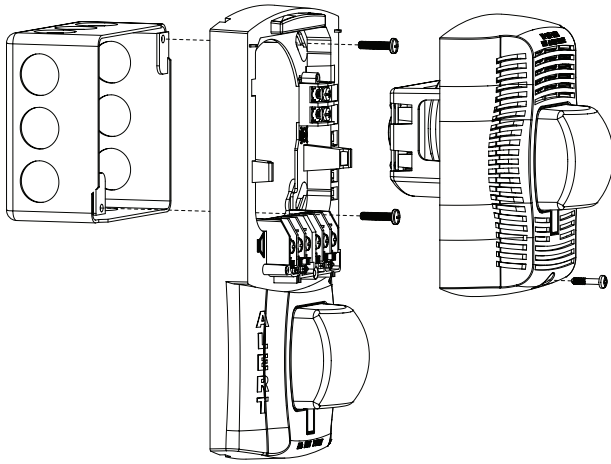

SEP-SPSW for flush-mount applications

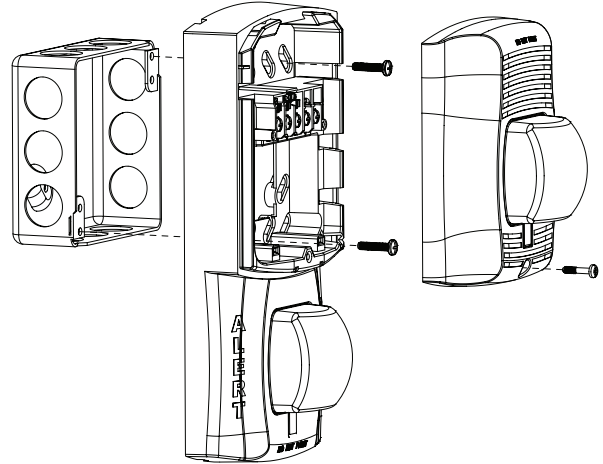

SEP-SW for flush-mount applications

Surface Mounting

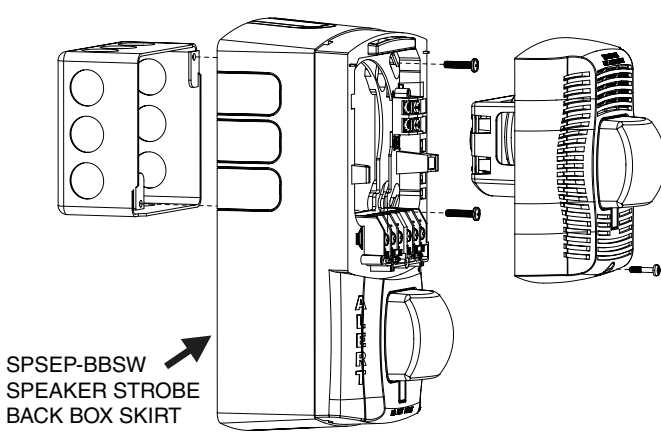

SPSEP-BBSW
SPEAKER STROBE
BACK BOX SKIRT

SEP-SPSW for surface-mount applications

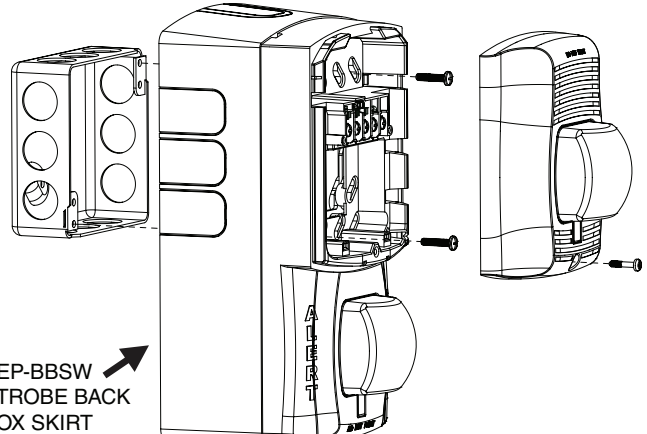

SEP-BBSW
STROBE BACK
BOX SKIRT

SEP-SW for surface-mount applications

Ordering Information

Wall Mount	
White	Description
SEP-SPSW	Speaker Strobe Expander Plate, Standard Candela, White Compatible with SPSW, SPSWH, SPSW-P, SPSWV, SPSWV-P, SPSWH-P
SEP-SW	Strobe Expander Plate, Standard Candela, White Compatible with SW, SWH, SW-P, SWH-P
SPSEP-BBSW	Speaker Strobe Expander Plate Back Box Skirt, White Compatible with SEP-SPSW
SEP-BBSW	Strobe Expander Plate Back Box Skirt, White Compatible with SEP-SW



3825 Ohio Avenue • St. Charles, IL 60174
Phone: 800-SENSOR2 • Fax: 630-377-6495

©2012 System Sensor.
Product specifications subject to change without notice. Visit systemsensor.com
for current product information, including the latest version of this data sheet.
AVDS01301 • 3/12