

## 2112/24D(A) and 2112/24TD(A) Photoelectronic Smoke Detectors

### IMPORTANT: OBSERVE POLARITY

**This detector requires that you observe polarity when wiring. If wiring polarity is not observed on the initiating loop, the unit will send an alarm signal to the control panel to signify incorrect wiring.**

**Figure 1. Wiring diagram for the 2112/24D(A) and 2112/24TD(A) detectors:**

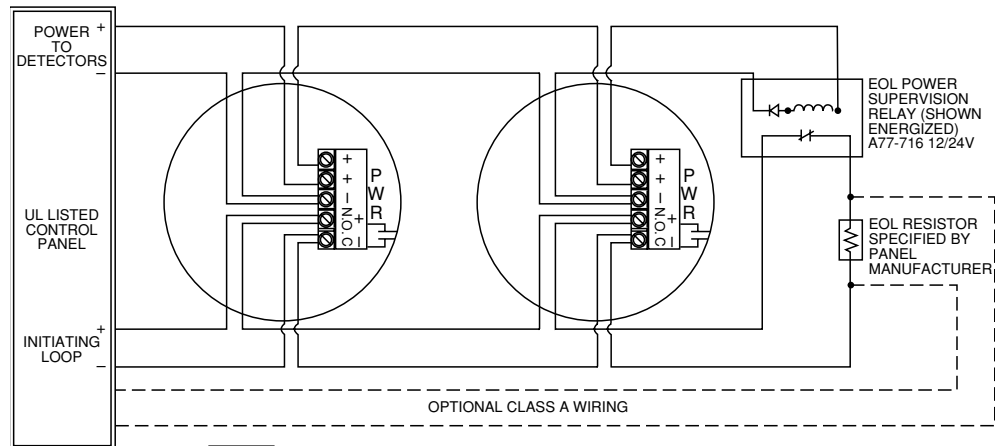

**NOTE:** Observe polarity in power and initiating loops when wiring.

A78-2336-03

### Before Installing

Please thoroughly read the System Sensor manual I56-407, *Guide for Proper Use of System Smoke Detectors*, which provides detailed information on detector spacing, placement, zoning, wiring, and special applications. Copies of this manual are available at no charge from System Sensor. (For installation in Canada, refer to CAN/ULC-S524-M91, *Standard for the Installation of Fire Alarm Systems*, and CEC Part 1, sec. 32.)

**NOTICE:** This manual should be left with the owner/user of this equipment.

**IMPORTANT:** This detector must be tested and maintained following NFPA 72 requirements. The detector should be cleaned at least once a year.

### General Description

Model 2112/24D(A) is a 4-wire photoelectronic smoke detector that uses a state-of-the-art optical sensing chamber. This detector is designed to provide open area protection. Model 2112/24TD(A) features a restoreable, built-in, fixed-temperature (135°F) thermal detector.

Installation of these detectors is simplified by the use of a mounting bracket and a plug-in screw terminal block that

can be prewired to the system, allowing the detector to be easily installed or removed for cleaning. The detector's sensitivity can be tested in place using the MOD400R Test Module.

An LED on the detector provides a local visual indication of the detector's status. If power is applied to the detector, and it is functioning normally in standby, the status LED blinks every ten seconds. The LED also latches on in alarm.

Models 2112/24D(A) and 2112/24TD(A) feature a visual indication that maintenance is required – if the sensing chamber drifts out of its sensitivity limits, the LED ceases to blink.

### Mounting

Each 2112/24D(A) and 2112/24TD(A) detector is supplied with a mounting bracket that permits the detector to be mounted:

1. To a single gang box, or
2. Directly to a 3<sup>1</sup>/<sub>2</sub>-inch or 4-inch octagonal box, or
3. To a 4 inch square electrical box by using a plaster ring.

### Tamper-resistant Feature

This detector includes a tamper-resistant feature that prevents its removal from the bracket without the use of a

---

## Specifications

Diameter:	5.5 inches (140 mm)
Height (including mounting bracket):	1.7 inches (43 mm)
Weight:	5.3 oz. (150 g)
Operating Temperature Range	
Model 2112/24D(A):	32° to 120°F (0° to 50°C)
Model 2112/24TD(A):	32° to 100°F (0° to 39°C)
Operating Humidity Range:	10% to 93% Relative Humidity, Noncondensing
Latching Alarm:	Reset by momentary power interruption
Heat Sensor (2112/24TD(A) only):	135°F Fixed Temperature Electronic Thermistor

## Electrical Ratings

System Voltage (nominal):	12 or 24 VDC
Minimum:	8.5 VDC
Maximum:	35 VDC
Maximum Ripple Voltage:	30% of nom. Voltage (peak to peak)
Standby Current:	50 $\mu$ A maximum
Alarm Current:	17 mA typical, 23 mA max. at 12V 19 mA typical, 25 mA max. at 24V
Reset Voltage:	0.8 VDC minimum
Reset Time:	0.3 seconds maximum
Start-up Time:	30 seconds maximum (after 60 sec. reset)
EOL Relay:	A77-716B, 12/24 Volt
Alarm Initiation Contact Ratings	
Resistive Load:	0.1A @ 35 VDC

---

**Figure 2. Surface mounting of 2112/24D(A) smoke detector on 3<sup>1</sup>/<sub>2</sub>-inch and 4-inch octagonal box:**

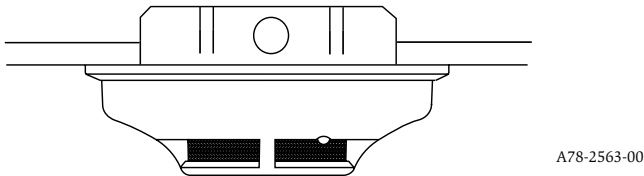

tool. To make the detector tamper-resistant, remove the smaller tab by breaking it at the scribed line on the tamper resistant tab on the detector mounting bracket (see Figure 3), then install the detector. To remove the detector from the bracket once it has been made tamper resistant, use a small screwdriver to depress the tamper-resistant tab, located in the slot on the mounting bracket, and turn the detector counterclockwise.

## Wiring Installation Guidelines

**CAUTION**

Be certain to observe polarity when wiring.

All wiring must be installed in compliance with the National Electrical Code, applicable local codes, and any special requirements of the local authority having jurisdiction. Proper wire gauges should be used. The conductors used to connect smoke detectors to control panels and accessory

devices should be color-coded to reduce the likelihood of wiring errors. Improper connections can prevent a system from responding properly in the event of a fire.

The screw terminal block accepts 14 – 22 gauge wire. For best system performance, all wiring should be installed in separate grounded conduit. Do not mix fire system wiring in the same conduit as any other electrical wiring. Twisted pair may be used to provide additional protection against electrical interference.

Smoke detectors and alarm system control panels have specifications for allowable loop resistance. Consult the control panel specifications for the total loop resistance allowed for the control panel being used before wiring the detector loops.

Wire connections are made by stripping about 1/4 inch of insulation from the end of the feed wire, inserting the wire into the appropriate terminal, and tightening the screw to secure the wire in place.

## Installation

**WARNING**

Remove power from the control unit or initiating device circuits before installing detectors.

---

**Figure 3. 2112/24D(A) and 2112/24TD(A) smoke detector mounting bracket:**

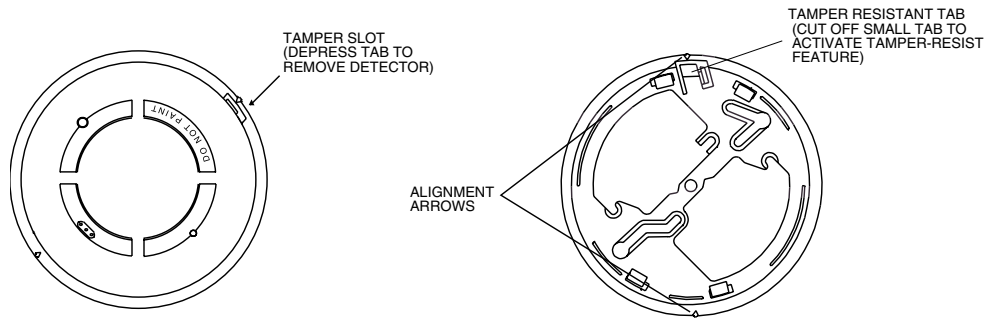

A78-2333-01

1. Wire the plug-in screw terminal block per Figure 3 and plug the terminal block into the detector.
  2. Align the arrows on the detector with the arrows on the mounting bracket.
  3. Turn the detector clockwise in the mounting bracket until it clicks into place.
  4. After all detectors have been installed, apply power to the control unit or initiating device circuits.
- NOTE: This detector has a feature that will signal an alarm at the control panel if wiring polarity is incorrect.**
5. Test the detector as described in **TESTING**.
  6. Reset the detector at the system control panel.
  7. Notify the proper authorities the system is in operation.

**CAUTION**

Dust covers are an effective way to limit the entry of dust into smoke detector sensing chambers. However, they may not completely prevent airborne dust particles from entering the detector. Therefore, System Sensor recommends the removal of detectors before beginning construction or other dust producing activity. Be sure to remove dust covers from any sensors that were left in place during construction as part of returning the system to service.

**Testing**

**NOTE:** Before testing, notify the proper authorities that the smoke detector system is undergoing maintenance and will be temporarily out of service. Disable the zone or system undergoing maintenance to prevent unwanted alarms.

Detectors must be tested after installation and following

periodic maintenance. Test the 2112/24D(A) as follows:

- A. Test Switch
  1. A recessed test switch is located on the detector housing (See Figure 4).
  2. Press and hold the recessed test switch with a 0.18 inch maximum diameter tool such as an allen wrench or small screwdriver.
  3. The detector's LED should light within 5 seconds.
- B. Test Module (System Sensor Model No. MOD400R)  
The MOD400R test module can be used with a DMM or analog voltmeter to check the detector sensitivity as described in the test module's manual.
- C. Smoke Entry Test  
Hold a smoldering punk stick or cotton wick at the side of the detector and gently blow smoke through the detector until the unit alarms.
- D. Direct Heat Method (Model 2112/24TD(A) only - Hair dryer of 1000-1500 watts)  
Direct the heat toward either of the side thermistors. Hold the heat source about 12 inches from the detector in order to avoid damage to the plastic. The detector will reset only after it has had sufficient time to cool and the power source has been momentarily interrupted.

Both smoke and heat detection testing are recommended for verifying system protection capability.

A detector that fails to activate with any of the above tests should first be cleaned as outlined in **MAINTENANCE**. If the detector still fails to activate, return it for repair.

Notify the proper authorities the system is back in operation.

**Figure 4. Top and side views showing position of test switch:**

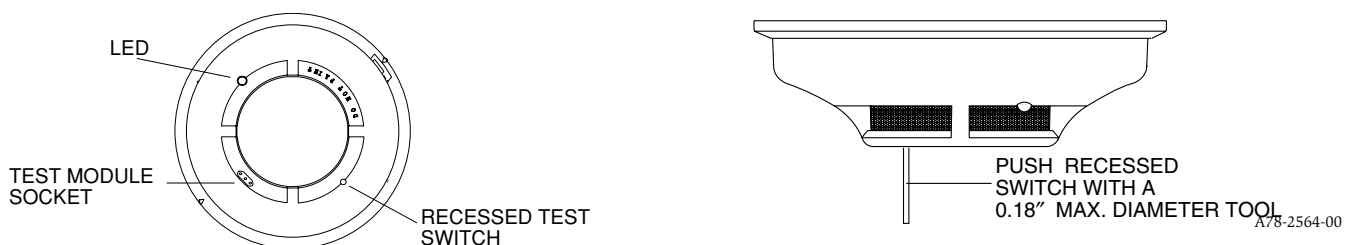

A78-2564-00

## Maintenance

**NOTE:** Before removing the detector, notify the proper authorities that the smoke detector system is undergoing maintenance and will be temporarily out of service. Disable the zone or system undergoing maintenance to prevent unwanted alarms.

**NOTE: (Model 2112/24TD(A) only)** Before removing the detector cover, note the position of the thermistors. Make sure the thermistors are not bent over when the housing is replaced.

1. Remove the detector housing by gently prying the four housing tabs on the bottom of the base with a small-bladed screwdriver and pull the housing from the base. Use caution to avoid damaging the thermistors (2112/24TD(A) only).
2. Vacuum the screen carefully without removing it.
3. Remove screen assembly, pulling straight out (see Figure 5).
4. Remove the sensing chamber cover.
5. Clean the sensing chamber by vacuuming or blowing out dust and particles.
6. Replace the sensing chamber cover, aligning the arrow on the cover top with the arrow on the printed circuit board.
7. Replace the screen by placing the screen assembly over the sensing chamber cover and twisting until it snaps into place.

**Figure 5. Removal of cover and screen for cleaning:**

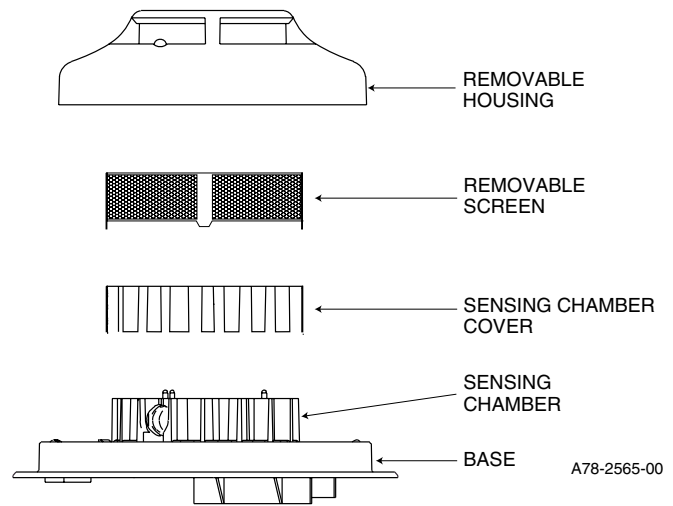

8. Replace the housing by aligning the three triangular slots on the base with their counterparts on the housing. Gently press the housing until it locks in place. Check to make sure that the thermistors are in the upright position (2112/24TD(A)).
9. Reinstall the detector.
10. Notify the proper authorities that the system is back in operation.

### ⚠ WARNING

#### The Limitations of Property Protection Smoke Detectors

This smoke detector is designed to **activate and initiate** emergency action, but will do so only when it is used in conjunction with an authorized fire alarm system. This detector must be installed in accordance with NFPA standard 72. (For installation in Canada, refer to CAN/ULC-S524-M91, *Standard for the Installation of Fire Alarm Systems*, and CEC Part 1, sec. 32.)

**Smoke detectors will not work without power.** AC or DC powered smoke detectors will not work if the power supply is cut off.

**Smoke detectors will not sense fires which start where smoke does not reach the detectors.** Smoldering fires typically do not generate a lot of heat which is needed to drive the smoke up to the ceiling where the smoke detector is usually located. For this reason, there may be large delays in detecting a smoldering fire with either an ionization type detector or a photoelectric type detector. Either one of them may alarm only after flaming has initiated which will generate the heat needed to drive the smoke to the ceiling.

Smoke from fires in chimneys, in walls, on roofs or on the other side of a closed door(s) may not reach the smoke detector and alarm it. A detector cannot detect a fire developing on another level of a building quickly or at all. For these reasons, detectors **shall be located on every level and in every bedroom within a building.**

**Smoke detectors have sensing limitations, too.** Ionization detectors and photoelectric detectors are required to pass fire tests of the flaming and smoldering type. This is to ensure that both can detect a wide range of types of fires. Ionization detectors offer a broad range of fire sensing capability but they are somewhat better at

detecting fast flaming fires than slow smoldering fires. Photoelectric detectors sense smoldering fires better than flaming fires which have little, if any, visible smoke. Because fires develop in different ways and are often unpredictable in their growth, neither type of detector is always best, and a given detector may not always provide early warning of a specific type of fire.

In general, detectors cannot be expected to provide warnings for fires resulting from inadequate fire protection practices, violent explosions, escaping gases which ignite, improper storage of flammable liquids like cleaning solvents which ignite, other similar safety hazards, arson, smoking in bed, children playing with matches or lighters, etc. Smoke detectors used in high air velocity conditions may have a delay in alarm due to dilution of smoke densities created by frequent and rapid air exchanges. Additionally, high air velocity environments may create increased dust contamination, demanding more frequent maintenance.

To keep your equipment in excellent working order, ongoing maintenance is required per the manufacturer's recommendations and UL and NFPA standards. At a minimum, the requirements of Chapter 7 of NFPA 72, the National Fire Alarm Code, shall be followed. A preventative maintenance agreement should be arranged through the local manufacturer's representative. Though smoke detectors are designed for long life, they may fail at any time. Any smoke detector, fire alarm equipment, or any component of that system which fails shall be repaired or replaced as soon as possible.

#### Three-Year Limited Warranty

System Sensor, Inc. warrants the detector to be free from defects in materials and workmanship for a period of three years from the date of manufacture. No agent, representative, dealer, or employee of the Company has the authority to increase or alter the obligations or limitations of this Warranty. The Company's obligation of this Warranty shall be limited to the repair or replacement of any part of the smoke detector which is found to be defective in materials or workmanship under normal use and service during the three year period commencing with the date of manufacture. After phoning System Sensor's toll free number 800-SENSOR2 (736-7672) for a Return Authorization number, send defective units postage prepaid to: System Sensor, Repair Department, RA # \_\_\_\_\_, 3825 Ohio Avenue, St. Charles, IL 60174. Please include a note describing the malfunction and

the date of purchase. This warranty does not cover damage caused by fire, flood, or other causes of failure. The Company shall not be obligated to repair or replace units which are found to be defective because of damage, unreasonable use, modifications, or alterations occurring after the date of manufacture. In no case shall the Company be liable for any consequential or incidental damages for breach of this or any other Warranty, expressed or implied whatsoever, even if the loss or damage is caused by the Company's negligence or fault. Some states do not allow the exclusion or limitation of incidental or consequential damages, so the above limitation or exclusion may not apply to you. This Warranty gives you specific legal rights, and you may also have other rights which vary from state to state.